



Length overall 53³/₄ "
Width overall 30 "
Height overall 46 "
Weight approx. 240 kg

korrex

Andruckpressen

Proofing presses



**Type Stuttgart
manual press**

Format 13³/₄" x 17⁵/₁₆"

korrex

I Type Stuttgart manual press Format 13^{3/4}" x 17^{5/16}"

A very carefully and accurately made small-format proofing press for composing rooms.

Print conditions equivalent to those on high-speed presses. Strong fixed printing bed.

Bed and bearers are ground. Helically toothed racks.

Side guideways with interchangeable hardened and ground steel rails.

Impression cylinder with cast-in continuous steel shaft.

High cylinder tensioning, fingertip ease of movement.

Accurate sheet feeder and gripper equipment with micrometer adjustment.

Blanket is easily changed.

Travelling delivery.

Micrometer side lays in steel rail marked off in cm or inch divisions.

Sheets are smoothed by two adjustable rotary brushes.

Highly accurate register.

Inking unit with 2 forme-inking rollers and 1 spreading roller.

Ink is spread by operation of a small hand crank.

The inking unit is easy to take out. Inking table to increase inking capacity.

The ink table can be hung below the machine when not in use.

Distance between racks: 35 cm.



Impression cylinder at end of run

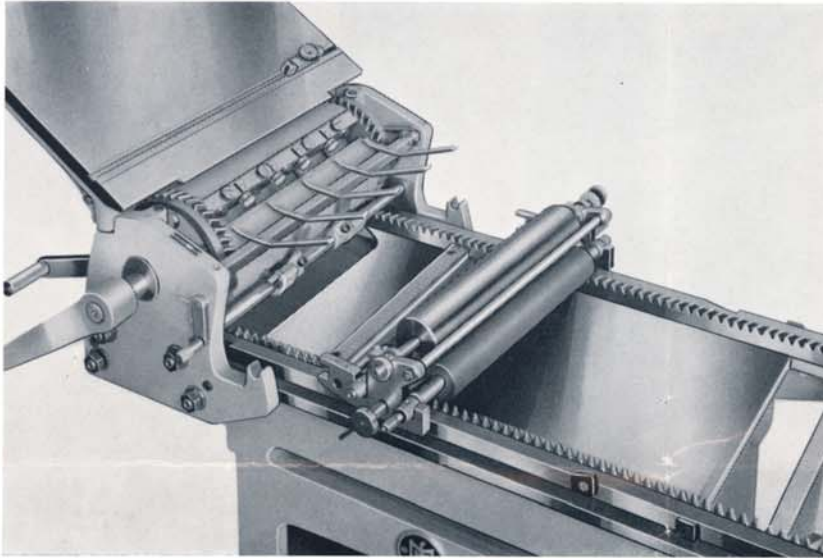

Inking unit disengaged

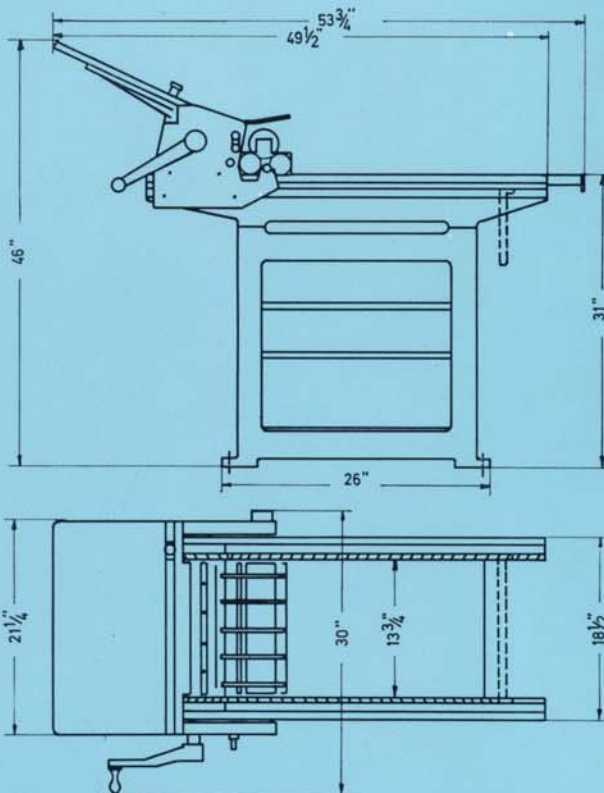

Leading dimension

Standard accessories: (Included in price of machine)

One set of tools, oilcan, type-high cylinder gauge.

Special accessories:

Quick-closing reglet.
Forme with or without built-in locks.
Grooved bed with block holders and stops.
Vacuum bed with vacuum pump.
Cellophane smoothing equipment.

MAX SIMMEL
MASCHINENFABRIK
753 PFORZHEIM

KAISER-FRIEDRICH-STRASSE 24
FERNSPRECHER 07231 - 33327/8